

Tapped holes for WIKA pressure connections

WIKA Data Sheet IN 00.14

Applications

- For the mounting and sealing of WIKA pressure measuring instruments

Versions

- For standard pressure connections
- For pressure connections, flush diaphragm

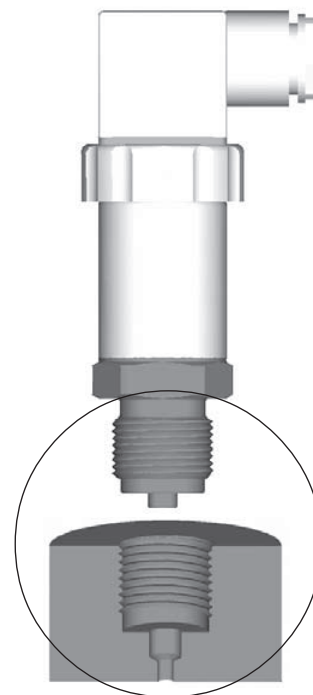

Description

WIKA offers pressure measuring instruments with a wide range of pressure connections in order to meet the customers' diverse and specific application requirements.

For the installation of the pressure measuring instruments the customer has to provide a suitable tapped hole to accommodate the WIKA pressure measuring instrument.

The decisive criterion for the selecting of a suitable tapped hole is the pressure connection.

Pressure connections are mainly divided into standard and flush diaphragm connections.

Furthermore, the thread type of the pressure connection and the sealing washer are also decisive factors.

Types of threads

WIKA offers pressure connections with various types of threads that are frequently used worldwide.

Types of sealing washers

Depending on the pressure connection and the measuring medium, various types of sealing washers and sealing materials can be used.

Depending on the pressure connection, the location where the sealing washer is used may vary.

For further information see page 2. In order to make the assignment of suitable tapped holes to the pressure connections easier for you, we have indicated the WIKA (order) code of the pressure connection.

WIKA offers several tapped holes as welding sockets. They may be ordered stating the WIKA order No. indicated.

Tapped holes for pressure connections, standard version

Standard version (sealing by means of profile packing)

DIN 3852-X-G1/4
Code: HD

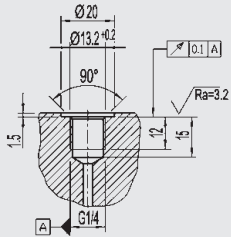

DIN 3852-X-G1/2

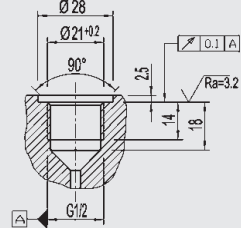

DIN 3852-X-G1 1/2 **)
Code: G6
Order-No: 2158982

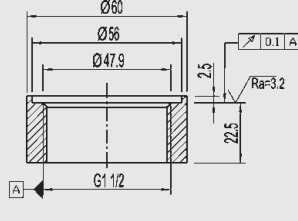

only with model MH-1:
DIN 3852-X-M12x1,5
Code: MK

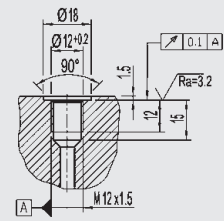

DIN 3852-X-M14x1,5
Code: HN

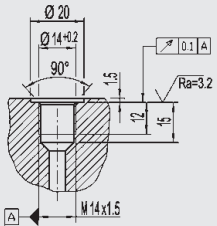

DIN 3852-X-M18x1,5
Code: MG

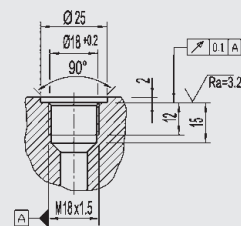

1/4NPT „Nominal size
for US standard tapered
pipe thread NPT“
Code: NB

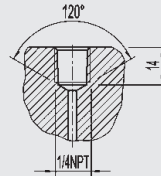

1/2NPT „Nominal size
for US standard tapered
pipe thread NPT“
Code: ND

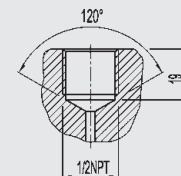

Version according to standard EN 837 (for pressure connections with standard connector)

EN 837 G1/4
Code: GB, RE

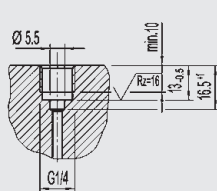

EN 837 G1/2
Code: GD, RB

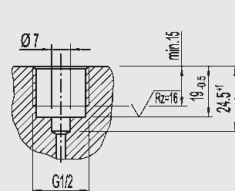

Version according to standard SAE J 514

SAE J 514 7/16-20 UNF
Code: UA

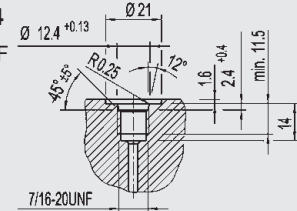

Tapped holes for pressure connections, flush diaphragm (Version WIKA-specific)

G1/4 *)
(with O-Ring)
Code: 88

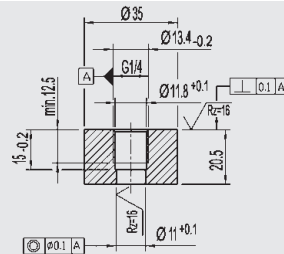

G1/2 *) **)
(with O-Ring)
Code: 86
Order-No: 1192299

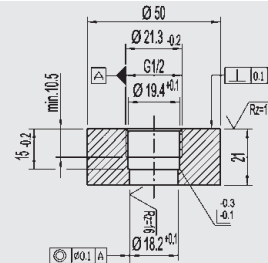

G1 *) **)
(with O-Ring)
Code: 85
Order-No: 1192264 *)
(metal sealing cone)
Code: 87
Order-No: 1524380

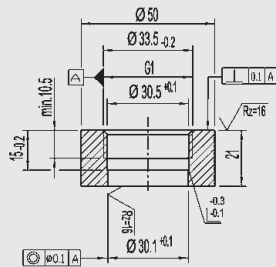

G1 EHEDG 1) *) **)
Code: 83
Code: 84 (up to 150°C)
Order-No: 2166011

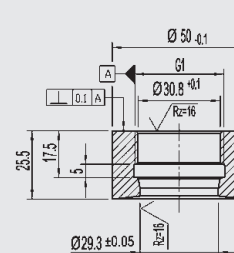

*) The tapped holes provided by the customer have to be drilled after the tapping.

**) Also available from WIKA as welding sockets.

1) European Hygienic Equipment Design Group

WIKA strives to keep the tapped holes represented up-to-date. The construction of the tapped holes is governed by the latest relevant standards and regulations. Technical modifications of the design of the WIKA-specific tapped holes and welding sockets may take place without prior notice.



WIKAL Alexander Wiegand GmbH & Co. KG
Alexander-Wiegand-Straße 30
63911 Klingenberg/Germany
Phone (+49) 93 72/132-0
Telefax (+49) 93 72/132-406
E-Mail support-tronic@wika.de
www.wika.de